

The Chiller



Everyone is health conscious these days. So, you want your staff, customers and visitors to have access to high quality drinking water – but you don't want any hassle.

We can offer a refreshingly simple answer: **The Chiller**

The Chiller mains-fed water dispenser, delivers an instant and constant supply of high quality drinking water. Because the chiller unlike bottled water coolers, is mains-fed, it does away with the problems of storage, lifting heavy water bottles, degradation and sanitisation, not to mention running out.

Instead, you get features such as ergonomic design that complements every environment and 'direct chill' technology to guarantee fresh water every time.

Features:

Direct chill technology

Constant supply of chilled filtered water

Carbon Filtration

The Chiller

Options

Colours Silver/black

Water Cold only

Size Freestanding

Machine weight The Chiller cold only counter top: 22kg
The Chiller cold only freestanding: 25kg

Installation Requirements

To ensure that the Watercooler can be installed quickly and smoothly in your proposed location, each machine will require a 13amp (240 AC) switched socket which should not be more than one metre from the machine. Each plumbed water machine needs to be supplied with water from a rising main. Machines cannot be connected to a storage tank water supply. The pipe work should ideally be no more than one metre from the machine although our in-house service team are able to install machines in the majority of locations. Pipe work must be terminated with a 15mm BS1010 stopcock.

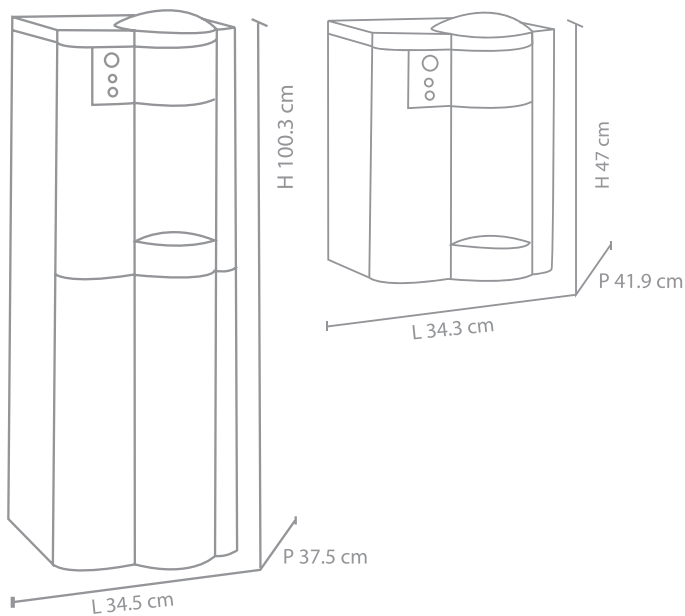

Technical Information

